

THE EFFECT OF ROTATING-BENDING FATIGUE ON HIGH-DENSITY POLYETHYLENE

Ioana-Daniela Manu¹

¹ Petroleum-Gas University of Ploiesti, Romania
e-mail: ioana.manu@upg-ploiesti.ro

DOI: 10.51865/JPGT.2022.01.08

ABSTRACT

External factors, such as main stresses, frequency of the loading, shape and history of loading (hysteresis) have an important effect on the fatigue behavior of high-density polyethylene. HDPE pipes, used in the transport and distribution of water and are required for oscillating loads caused by internal pressure or external loads. These cyclic loads cause the pipe's failure due to fatigue. In a polymer fatigue occurs at stress levels that are low relative to the yield strength [1]. This paper presents results from the assessment of the mechanical behavior of specimen test taken from PE 100 pipe in the case of variable stresses. Thus, compressive and tensile stresses are induced on the specimen test as it is simultaneously bent and rotated. The rotating-bending fatigue test is performed when the specimen test is placed with the extremities on two supports and supports a load applied in four-points placed symmetrically with respect to the supports, at 1/3 of the distance between the supports, according to [2]. The effect of the values of the number of cycles until failure in the case of rotating-bending fatigue stress on mechanical properties of HDPE is also compared with the same factor in the case of axial fatigue stress. The polyethylene pipe may be subjected to random variable stresses. In practice, variable loading patterns as strain rate, temperature, hydrostatic pressure, pressure from to the vehicle wheels, the movement and the variable weights supported by the surrounding soil are causes that could lead to the bending of PE pipe. These loads generate oscillating axial stresses. The bending of the pipe is cause of the cross-section modification (roundness modification) of it.

Keywords: fatigue, stress, load, bending, pipe

INTRODUCTION

The specialized technical literature [3-7] specified the influence of molecular weight and the crystallization degree or the concentration of tie molecules on characteristics in the case of HDPE fatigue. In addition, external factors and internal pressure have influence on the fatigue behavior of polyethylene of high density used in water transmission systems. The pipes are subjected on variable loading patterns: hydrostatic pressure, pressure due to the vehicle wheels, the movement and the variable weights supported by the surrounding soil. These cyclic loading determine pipeline failure through fatigue. From practice, was demonstrated the dependence between stress, even and at low level, and the pipeline failures. The correlation has as determined factor cyclical loads and is highlighted even in a relatively short operating time. In the case of variable loads, it is accepted that stress is a periodic function of time t . The set of stress

values during a period of time is called a cycle and is defined by the maximum stress σ_{max} and minimum stress σ_{min} . The ratio between minimum stress and maximum stress represents stress ratio.

Generally, knowing the yield stress σ_y of the material subjected to research, according to [8] the test specimen test was tested at symmetrical cycles with $\sigma_{max} = \sigma_I = (0.25 \dots 0.5) \sigma_y$. This value is corresponded a N_I number of cycles at which the specimen test is broken and the pair of values (σ_I, N_I) represents the point number 1 plotted in a coordinate system $\sigma_{max} - N$. Testing of next specimen provides second point (σ_2, N_2) for a stress of less than 1-2 MPa than the first. With a series of such points to a graph called Wöhler's curve or $S-N$ curve is constructed. In case of Wöhler's curve becomes horizontal at higher values of number of cycles fatigue limit is recorded. Below this fatigue limit will not occur fatigue failure. Also, fatigue strength σ_R is an important mechanical characteristic which describes the fatigue response. It represents the stress level at which the failure occurs for a given number of cycles. A certain level of stress in the $S-N$ curve corresponds to a number of cycles that cause failure, called fatigue life. Endurance limit is the maximum amplitude of completely reversed stress that a specimen test can sustain for an unlimited number of cycles, without fatigue failure.

The $S-N$ curve has 3 domains: I - Static or low cycle stress zone, II - limited durability zone, III - high cycle stress zone or unlimited durability zone (fatigue strength zone). Zones II and III are of interest for variable stress tests. In this sense, after recommendation the first determination must be made at the maximum stress at which the test piece can withstand at least 10^4 cycles.

Low cycle fatigue is considered when are involves higher applied cyclical stresses (and failure occurs fewer cycles. In this case, both elastic and elastic deformation occur.

For high cyclical fatigue the failure time is very long and high cycle fatigue occurs, after a very large number of cycles, more than 10.000 cycles, and deformation is totally elastic.

The same σ_{min} can be maintained when changing the load cycle.

The fatigue test is standardized and [9] specifies that long term fatigue test must be performed according to standards [10-11].

There are three standardization tests for fatigue:

- by rotating-bending;
- with axial loads;
- by twisting.

[12] notes that [13] is the standard that also applies to plastics. It establishes the method and conditions for testing, with alternating-symmetrical cycles of constant amplitude, on specimen test with a diameter between 5 and 12.5 mm without stress concentrators, in the conditions of the test ambient atmosphere, according to [14].

The probability of the association of material failure problems and the cyclic test is explained by the presence of intrinsic defects installed during the manufacturing process. The following characteristics are usually determined by the rotating-bending fatigue test: fatigue strength, resistance to limited durability, fatigue limit. Fatigue resistance is the highest value of the maximum stress at which the specimen test does

not break, being subjected to a large number of stress cycles (asymptote on the Wöhler's curve), denoted by σ_R and shown, according to [15], in Figure 1.

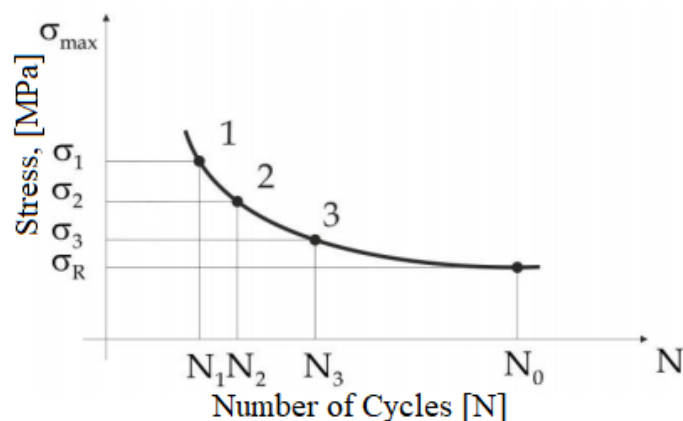

Figure 1. Positioning the fatigue strength on the Wöhler curve [13]

According to [16, 17], in determining the rupture of the HDPE material, three fatigue yield models are used, namely: Miner's linear rule, the yield stress model DS, and the yield energy model DE, respectively. Each expresses its own calculation of the yield, either by a variable D_i , in the case of the first model, or by a yield indicator D , in the case of the second model, or by a relative prediction error, in the model three. The behavior of HDPE material on axial fatigue test specimens was investigated. In addition, a comparison of the three models was made and it was found that Miner's rule provides the closest predictions to the experimental results.

EXPERIMENTAL PROCEDURE

The rotating-bending fatigue test proposes the behavioral evaluation of the HDPE material at the rotating-bending stress for a study compared to the one demonstrated in the case of axial fatigue stress. The specimen test for rotating-bending fatigue test were prepared from PE 100 pipe. The test has purposed the evaluation its behavior in case variable overloads, repeated a large number of times. In this sense, the degree of decrease of the mechanical resistance due to the installation of the fatigue phenomenon of the material is followed. The evaluation of the fatigue strength of the material, the behavioral analysis and the determination of the Wöhler's curve or the durability curve for PE 100 are the targets of the experiment.

The test consists in the application, generally to the point of rupture, perpendicular to the longitudinal axis of the specimen test in rotation, of a load which produces a bending moment. The maximum number of cycles up to which the tests are performed is practically limited to $N = 10^7$, considering that if the specimen test did not yield up to this number of cycles, then the test body will not yield to a larger number.

The rotating-bending fatigue test on a specimen test shall be performed according to [12], when it is placed with the extremities on two supports and bears an applied load. The load can be applied in different ways:

- central, according to [18] and [19];
- at two points symmetrically to the supports, 1/3 of the distance between the supports, in accordance with [20];
- at one end while the other end is recessed in accordance with [21].

For the rotating-bending fatigue test performed, the loads were applied in four-points placed symmetrically with respect to the supports.

In the case of the experiment, loads were applied constantly throughout the test, continuously, without shocks and at the set frequency. The conditions established for the conduct of the experiment, such as load, frequency and diameter of the specimen test, were chosen appropriately to avoid heating in the calibrated area of the specimen test at a temperature above 100 °C.

The experiment took place in the Laboratory of Complex Mechanical Tests C II 9 - LEIMC 2 Complex Mechanical Tests 2 of Petroleum-Gas University of Ploiesti. Was used a rotating-bending fatigue testing machine Type UBM 20 Nm, shown in figure 2a, manufacturer Walter + Bai Ag. The weight what producing the rotating-bending fatigue stress of the PE 100 specimen test and its positioning are shown in figure 2b.



a



b

Figure 2. The installation used to perform the experiment

The specimen test subjected to the request for rotating-bending fatigue test was cut directly from HDPE water pipe, from the longitudinal direction. The PE 100 pipe ($\text{Ø } 200 \times 14.7$) SDR 13.6 has the mechanical characteristics, established in a previous tensile test, presented in table 1.

Table 1. Mechanical characteristics of the material of the PE 100

Mechanical characteristics at strain rates 10^{-2} s^{-1} ($v = 50 \text{ mm/min}$)	Symbol and measurement unit	Values
Young's modulus	E [MPa]	1100
Yield stress	σ_y [MPa]	26.2
Yield strain	ε_Y [%]	8
Tensile strength	σ_c [MPa]	33

Specimen test have a circular section, cylindrical in shape, for the application of force at four-points, shown schematically, according to [10], in figure 3. According [13] on cylindrical specimen test subjected to constant bending moment, the parallel test section shall be parallel within 0.025 mm.

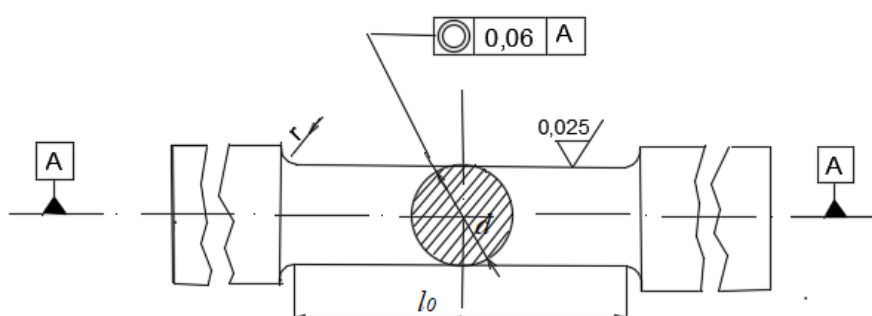

Figure 3. Schematic representation of the test piece subjected to rotating-bending

The dimensions of the test specimen test and the main technical characteristics that occurred as parameters in the applied procedure are given in table 2. It is a parallel specimen test, according to [13], with four-point loading. The limit deviations from the dimensions of the specimen test and its measurement accuracy were observed, according to [9, 13].

Table 2. Technical characteristics of the rotating-bending fatigue test

Technical characteristics	Symbol	Values
Diameter of specimen test where stress is maximum	d [mm]	10.02
Diameter of gripped or loaded end of specimen test	D [mm]	14.2
Radius at ends of test section that starts transition from test diameter	r [mm]	10
Calibrated length of the test piece	l_0 [mm]	31
Length of clamping end	l_p [mm]	29
Total length of the test piece	l [mm]	300
Load or applied force	F [N]	0.330
Constant bending moment	M [N·mm]	150
Fatigue life, cycles to failure	N_f [cycle]	20570

The processing of the specimen test was carried out in such a way as to preserve the structure and mechanical characteristics and to minimize the stresses remaining on the surface of the material. The image of the specimen test taken to be subjected to the experiment are shown in figure 4.



Figure 4. The specimen test taken to be subjected to the application of rotating-bending test

The way of holding the test piece in the tanks of the test machine complied with the requirements of [13]. As the test specimen is bent and rotated, each fiber is rotated and applied consecutively to tension and compression. The ratio stress was set at zero.

The sequence during the experiment is shown in figure 5a. The load application method, the bending moment, and the nominal stress diagrams, respectively, are shown in figure 5b.

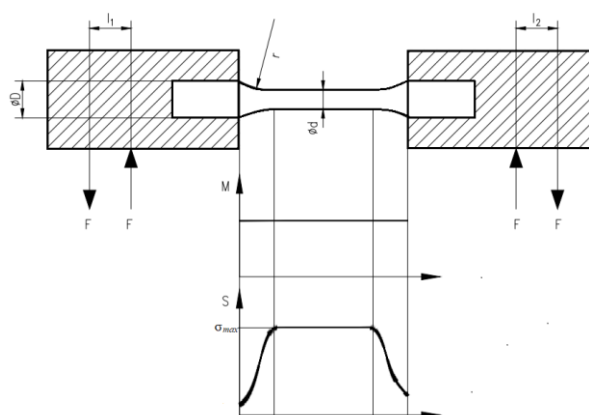
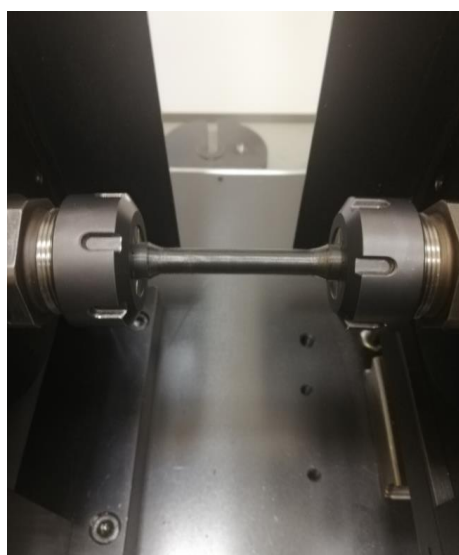

a

b

Figure 5. The specimen test subjected for rotating bending

According to [22], in the case of a request for rotating-bending, the aim is to change the shape of the specimen test under the action of bending moments caused by the weights suspended at the ends.

The specimen test is subjected to a bending stress σ , [MPa], whose calculation expression is given by relation (1).

$$\sigma = \frac{M}{W} \quad (1)$$

where:

σ – bending stress, [MPa];

M – bending moment, [N·mm];

W – modulus of strength, [mm³], defined by relation (2).

$$W = \frac{\pi d^3}{32} \quad (2)$$

The maximum stress that can be applied to the specimen test are determined, regarding the values of the geometric dimensions of the specimen test, specified in table 2, and the calculation relationship (3).

$$\sigma = \frac{32M}{\pi d^3} \quad (3)$$

In experimental test started from a maximum stress the same with that from [16, 17]. In table 3 are presented the results obtained, in which σ_1 – σ_4 is bending stresses or load stress and N_f that represents numbers of recorded cycles.

Table 3. The results of test for four-block loading

Changing the load cycle	σ_1 [MPa]	σ_2 [MPa]	σ_3 [MPa]	σ_4 [MPa]	N_1 [cycle]	N_2 [cycle]	N_3 [cycle]	N_4 [cycle]
Low to High	16	18	20	22	2.266	560	141	320
High to Low	22	20	18	16	70	141	560	20570

Figure 6 shows the panel of the rotating-bending fatigue test machine to highlight the number of stress cycles until which the specimen test does not break, respectively

$N_0 = 20570$.



Figure 6. Test machine panel

The frequency of the machine loading cycles was between 1000 and 9000 cycles /min.

The results recorded during the experiment were the basis for the diagram shown in figure 7. This was built as a correspondence between the logarithm of lifetime, because the number of cycles of failure can be very large, for the horizontal axis, and applied stress range on the vertical axis. By fitting a curve to the data points to obtain what is known as S-N (Stress-Number of cycles to failure) curve.

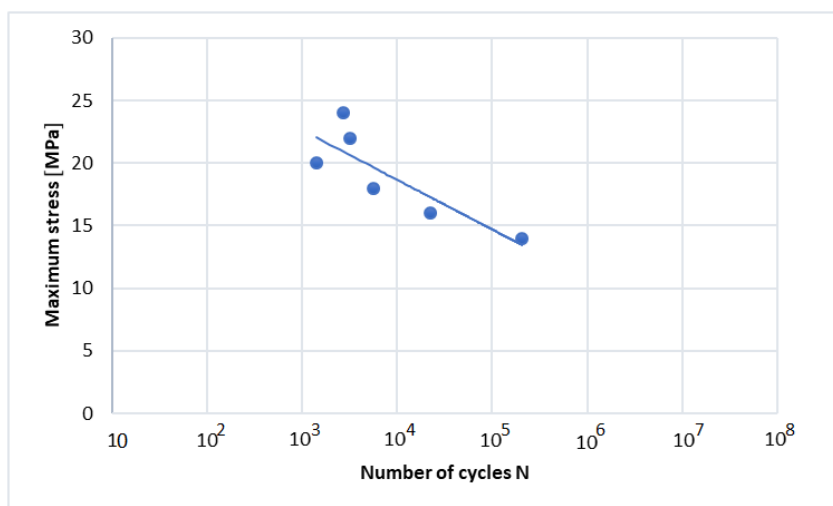

Figure 7. Wöhler's curve for the PE 100 study

The dependence between the maximum applied stress to the specimen test and the number of cycles on its rotational bending is approximately linear. Therefore, the conclusion reached by [16] and [17], respectively, regarding the aspect of the rational use of the Wöhler's curve modeling by Basquin's equation, given by the expression (4), is confirmed:

$$\log \sigma = -0.0728 \log N_f + \log 33.5 \quad (4)$$

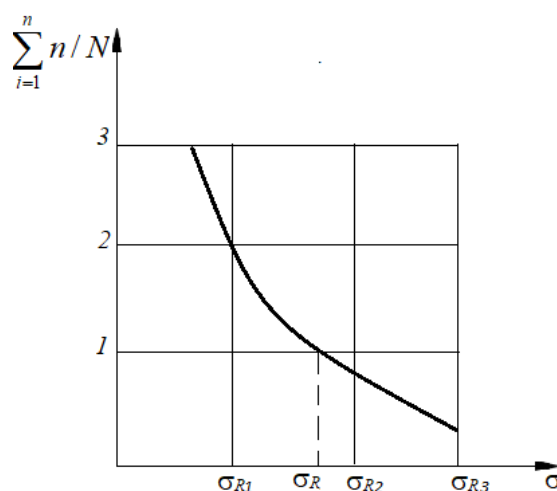

Figure 9. The diagram for determination of fatigue strength σ_R

CONCLUSION

According to [16, 17], the use of Miner's Rule, DE and DS models for HDPE, originally proposed for metallic materials, was for comparative purposes. Thus, for the axial fatigue load of the specimen test, it was found that Miner's linear model can be a good predictive tool for both the L-H and H-L loading cycles. The DS model can be considered an appropriate model for predicting the lifetime of high-density polyethylene. The DE model, similar in concept to the DS model, overestimates fatigue strength in both load cases.

Compared to the results presented by [16, 17], it was shown that the values of the number of cycles to failure, depending on the stress and strain are much lower in the case of axial fatigue stress than those obtained at rotational bending fatigue.

Because at the registration of 20570 stress cycles by the test machine the specimen test did not break and its testing was discontinued is recommended that a new rotating-bending test to carried out. In this condition

An important conclusion would be that bending stresses (which can lead in PE pipes buried at cross-section modification (roundness modification)) cannot lead to the failure of PE pipes.

REFERENCES

- [1]. Mechanical Properties. (n.d.). Analytical Techniques in the Sciences, pp. 230. doi:10.1002/9780470511343.
- [2]. *** ASTM D 790 Flexural Properties Testing of Unreinforced and Reinforced Plastics, 1971.
- [3]. Runt, J., Jacq, M. Effect of crystalline morphology on fatigue crack propagation in polyethylene, Journal of Material Science, USA, vol. 24, pp 1421-1428, 1989.

- [4]. Nishimura H., Narisawa I., Fatigue behavior of medium – density polyethylene pipes, *Polymer Engineering & Science*, Japan, vol. 31/issue 6, pp 399-403, 1991.
- [5]. Strebel J.J., Moet A., The effects of annealing on fatigue crack propagation in polyethylene, *Journal of Polymer Science Part B: Polymer Physics*, USA, vol. 33/issue 13, pp 1969-1984, 1995.
- [6]. Lu X., Qian R., Brown N., The effect of crystallinity on fracture and yielding of polyethylenes, *Polymer*, USA, vol. 36/issue 22, pp 4239-4244, 1995.
- [7]. Chen H., Scavuzzo R. J., Srivatsan T.S., Influence of joining on the fatigue and fracture behavior of high-density polyethylene pipe, *Journal of Materials Engineering and Performance*, USA, vol. 6/ pp 473-480, 1997.
- [8]. Mocanu D.R, The strength of materials, Technical Publishing House, Romania, 1980, pp. 766.
- [9]. Zecheru Gh., Drăghici Gh, Elements of materials science and engineering, ILEX and University of Ploiesti Publishing House, Romania, 2001, vol. 1, pp 242.
- [10]. *** NF T 51-120 Plastics and composites. Determination of the bending fatigue properties, 1995.
- [11]. *** ASTM D 671 Standard Test Method for Flexural Fatigue of Plastics by Constant-Amplitude-of-Force, 2002.
- [12]. Romanian Institute of Standardization, Collection of Commented Romanian Standards, Plastics, Romania, 1994, vol. 1.
- [13]. *** SR ISO 1143 Metallic materials. Rotating bar bending fatigue testing, 2012.
- [14]. *** STAS 6300 Standard conditioning and/or test atmospheres. Requirements, 1981.
- [15]. Mocanu R.D., Budescu M., Bliuc I., etc., Destructive attempts of metallic elements and non-metallic materials, Technical Publishing House, Romania, 1982, vol. 1, pp 189.
- [16]. Burchak M., Aid A., PE-HD fatigue damage accumulation under variable loading based on various damage models, *eXPRESS Polymer Letters*, Hungary, vol. 11/issue 2, pp 117-126, 2016.
- [17]. Abdelkader D., Mostefa B., Abdelkrim A., Noureddine B., Mohamed B., Fatigue life prediction and damage modelling of High-density polyethylene under constant and two-block loading, 3rd International Conference on Material and Component Performance under Variable Amplitude Loading, VAL2015, *Procedia Engineering*, vol. 101, pp 2-9, 2015.
- [18]. *** SR EN ISO 604 Plastic materials. Determination of compression properties, 2000.
- [19]. *** ISO 178 Plastics – Determination of flexural properties, 2019.
- [20]. *** ASTM D790 Flexure Testing of Plastics, 2017.



[21]. *** ASTM D747 Standard Test Method for Apparent Bending Modulus of Plastics by Means of a Cantilever Beam, 2010.

[22]. Ali S., Tahir M. H., Saeed M.A., Zaffar N., Khan M. K., Design and Development of Fatigue Machine: Rotating Bending Fatigue Testing of Different Materials, International Journal of Advanced Engineering and Management, India, vol. 4, no. 2, pp 8-15, 2019.

Received: April 2022; Accepted: June 2022; Published: June 2022